

Instruction Manual

Pallet Truck with Scale



Note: Owner/Operator must read and understand this instruction manual before using the pallet truck with scale.

RevB: 04/2007

Thank you for using this hand pallet truck with scale. For your safety and correct operation of the scale, please read these instructions carefully before using it.

- NOTE:** (1) All of the information reported herein is based on data available at the moment of printing. The factory reserves the right to modify its own products at any moment without notice and incurring any sanction. So it is suggested to always verify possible updates.
- (2) For systems with a printer, the rechargeable batteries must be charged before use, according to the instructions supplied with the batteries.

1. GENERAL SPECIFICATIONS

Model	Capacity	Graduation	Weighing Accuracy	Fork size			Net weight	
				Length	Width over forks	Fork Width		
ZF20S	Without printer	2000 kg	1 kg	±1‰	1150mm	555mm	180mm	136 kg
ZF20L	printer	2000 kg	1 kg	±1‰	1150mm	690mm	180mm	143 kg
ZFP20S	With printer	2000 kg	1 kg	±1‰	1150mm	555mm	180mm	136 kg
ZFP20L	printer	2000 kg	1 kg	±1‰	1150mm	690mm	180mm	143 kg

Materials and specifications are subject to change without notice.

2. TO ATTACH HANDLE TO PUMP UNIT

- 2.1 Loosen the setting screw (140H) on the crank link (139H).
- 2.2 Remove three screws (H109) and three spring washers (H110) from the base (103).
- 2.3 Place the handle (H101) on the base (103), please note: Feed the rod and chain (H107) through the centre of the base (103) and axle (109).
- 2.4 Insert three screws (H109) with spring washers (H110) into the base (103). Then tighten them securely.
- 2.5 Raise the crank link (139H) and put the pin on rod and chain (H107) into the groove of crank link (139H).

3. TO ADJUST RELEASE DEVICE

On the handle of the pallet truck, you will find the control lever (H106) which can be set in three positions (See Fig. 1): LOWER=to lower the forks; NEUTRAL=to move the load; ASCENT=to raise the forks. After assembling the handle, you can adjust the three positions.

- 3.1 First tighten the setting screw (140H) on the crank link (139H) until the LOWER position function works.
- 3.2 If the forks elevate while pumping in the NEUTRAL position, turn the setting screw (140H) clockwise until pumping the handle does not raise the forks and the NEUTRAL position functions correctly.
- 3.3 If the forks descend while pumping in the NEUTRAL position, turn the setting screw (140H) counter-clockwise until the forks do not lower.
- 3.4 If the forks do not descend when the control lever (H106) is in the LOWER position, turn the setting screw (140H) clockwise until raising the control lever (H106) lowers the forks. Then check the NEUTRAL position as per item 3.2 and 3.3.
- 3.5 If the forks do not lift while pumping in the ASCENT position, turn the setting screw (140H) counter-clockwise until the forks elevate while pumping in the ASCENT position. Then check the NEUTRAL and LOWER position as per item 3.2, 3.3 and 3.4.

4. MAINTENANCE

4.1 Oil

Please check the oil level every six months. The volume of oil is about 0.3lt. Use the hydraulic type oil according to temperature scale below.

Temperature	Oil
-20°C~+40°C	L-HV46 Hydraulic oil

4.2 How to expel air from the pump unit

Air may get into the hydraulics during transportation or when a pump is stored upside down. This can prevent the forks from lifting while pumping with the lever in the ASCENT position. The air can be expelled in the following way: Lift the control lever (H106) to the LOWER position, then move the handle (H101) up and down several times.

4.3 Daily check and maintenance

Daily check of the pallet truck will limit wear as much as possible. Give special attention to the wheels (127, F116 or F117), the axles (F114, F118, F121, F122), the handle (H101), the forks (F110) and lift and lower control. The forks should be unloaded and lowered in the lowest position when the job is over.

4.4 Lubrication

Use motor oil or grease to lubricate all moveable parts.

5. GUIDE TO SAFE OPERATION

For safe operation of the truck, please read all warning signs and instructions here and on the truck before using this truck.

- 5.1 Do not operate the pallet truck unless you are familiar with it and have been trained or authorized to do so.
- 5.2 Do not operate the truck unless you have checked its condition. Give special attention to the wheels, the handle assembly, the forks, lift and the lower control.
- 5.3 Do not use the truck on sloping ground.
- 5.4 Never place any part of your body in the lifting mechanism or under the forks or load. Do not carry passengers.
- 5.5 The operator should wear gloves and safety shoes for protection.
- 5.6 Do not handle unstable or loosely stacked loads.
- 5.7 Do not overload the truck.
- 5.8 Do not subject to unbalanced load, either side to side or along the length of the frame (refer to Fig. 2/B).
- 5.9 The capacity of the truck assumes an evenly distributed load with the centre of the load being at the half way point of the length of the forks (refer to Fig. 2)
- 5.10 Make sure that length of the forks matches the length of the pallet.
- 5.11 Lower the forks to lowest height when the truck is not being used.
- 5.12 At other specific conditions or places, the operator should operate the pallet truck carefully.

6. TROUBLESHOOTING

NO	TROUBLE	CAUSE	SOLUTION
1	The forks cannot be lifted to max. height	-There is not enough hydraulic oil.	-Pour in enough filtered oil.
2	The forks do not lift up.	-There is no hydraulic oil. -The oil has impurities. -Discharge valve is out of adjustment. -Air in the hydraulic oil.	-Pour in more filtered oil. -Change the oil. -Adjust the setting screw (140H) (See item 3.5). -Expel the air (See item 4.2).

3	The forks cannot be lowered.	-The rod (102) and the cylinder (159H) become deformed due to serious unbalanced load. -Component deformation due to unbalanced load. -The forks were kept at high position for long time with rod (102) bared which became rusty. -The setting screw (140H) is not in the correct position.	-Replace the rod (102) or cylinder (159H). -Repair or replace component to make it run smoothly. -Remove the rust on the rod (102). Keep the forks at lowered when not in use. -Adjust the setting screw (140H) (See item 3.4)
4	Leaks	-Seals worn out or damaged. -Some parts may be cracked or worn out.	-Replace seals with new ones. -Check and replace with new ones.
5	The forks descend without being lowered.	-Impurities in the oil cause the discharge valve (B) to fail to close. -Air in the oil. -Seals worn or damaged. -Discharge valve (B) is out of adjustment.	-Replace with filtered oil. -Expel the air (See item 4.2). -Replace with new ones. -Adjust the setting screw (140H) (See item 3.3).

***NOTE: DO NOT ATTEMPT TO REPAIR THE PALLET TRUCK UNLESS YOU ARE TRAINED AND AUTHORIZED TO DO SO.**

7. WEIGHING OPERATION

- 7.1 Put the control lever in the LOWER position and lower the truck to lowest position.
- 7.2 Press the key to turn the system on. After the start-up sequence the indicator will display the weight.
- 7.3 Weighing method for gross weight:
Press the →0← key to set the gross weight to 0. Put the forks under the pallet and check that the load is properly balanced. Put the control lever in the ASCENT position, pump the handle to make the forks rise until the pallet has left the ground. When the indicator is stable, the gross weight of the goods (total weight of the pallet and the goods) is shown.
- 7.4 Weighing method for net weight:
To display the weight of the goods without the weight of the pallet (or other container)
 - 7.4.1 Weigh single standard pallet, for example: weight of pallet: 40kg.
 - 7.4.2 Press the →0← key, the indicator will display "0kg".
 - 7.4.3 Remove the pallet from the forks, the indicator will display "-40kg".
 - 7.4.4 Weigh the goods on the pallet as shown in 7.3, when the indicator is stable, the net weight of the goods is shown.
- 7.5 Switch between kg and lb.
When the weight is shown in kg's, press the lb/kg key shortly and the unit shown will switch to lb. Press the lb/kg key again and the unit shown will switch back to kg.
- 7.6 Totaling (and printing if optional printer is present)
 - 7.6.1 Press the Σ to add the weight of the pallet to the total weight. If there is a printer, the weight of the pallet will be printed. **ATTENTION:**
-Weights below 20kg will not be added and printed (weight and measurement law).
-The scale needs to be unloaded before a 2nd weight can be added to the total or printed.
 - 7.6.2 Press and hold the Σ key to display the total weight. The weight of the pallet will not be added to total weight.
 - 7.6.3 When the total is shown, press the Σ shortly to reset the total weight to 0. If there is a printer, the total weight will be printed.
- 7.7 Turn off the Indicator
Press the Ⓞ key until the indicator displays "OFF". Releasing the key will turn off the indicator.

8. BATTERY POWER DATA AND REPLACEMENT

The indicator on the pallet truck scale uses 4 "AA" size batteries as power. You are recommended to use alkaline battery. Also you can use rechargeable batteries, which we recommend when there is a printer. Rechargeable batteries need to be charged, according to their own instructions, before they are first used. Change the batteries when  is shown in the display.

8.1 How to change batteries:

8.1.1 Loosen the screws on the battery cover and remove the cover.

8.1.2 Replace the 4 "AA" batteries in the battery holder, taking care to place them in the same direction.

8.1.3 Screw the battery cover plate back into position.

9. TROUBLESHOOTING OF WEIGHING UNIT

NO	TROUBLE	CAUSE	SHOOTING
1	HELP1 in the display	-The load is too big for the scale	-Remove the load immediately.
2	Text is not printed clearly on the ticket	-Battery voltage is too low	-Charge the batteries.
3	The scale is not accurate	-The fork shoe is touching the bottom part of the scale -Cable in junction box is loose. -1 of the load cells is broken	-Remove anything that restricts the movement of the scale. -Check the connection in junction box after confirming safe. -Stand on the 4 corners of the scale. The load cell in the corner with a different weight should be replaced.
4	Indicator can't be turned on.	-Battery voltage is too low. -Battery life is complete. -Charger is damaged.	-Charge the batteries. -Replace rechargeable battery with new ones. -Check charger output voltage replace charger with new one.
5	Battery can't be charged.	-Battery is damaged. -Charger is damaged.	-Replace rechargeable battery with new ones. -Check charger output voltage replace charger with new one.
6	Printer does not work Attention, printer is switched off automatically after printing. Line feed will only operate 3 seconds after a printout.	-The LED should be on being on constantly. If not: -The batteries are low. -The paper is finished -The printer is off line -Weight too small -The scale has not been unloaded -The paper is jammed	-Replace batteries -Replace paper roll -Button 1 is disabled to prevent the printer from being turned off-line. Check if this is the case by pushing the button once again -Lift a large weight (above 20kg). -Take off a weight before printing next weight -Reload the paper roll.

Fig.1

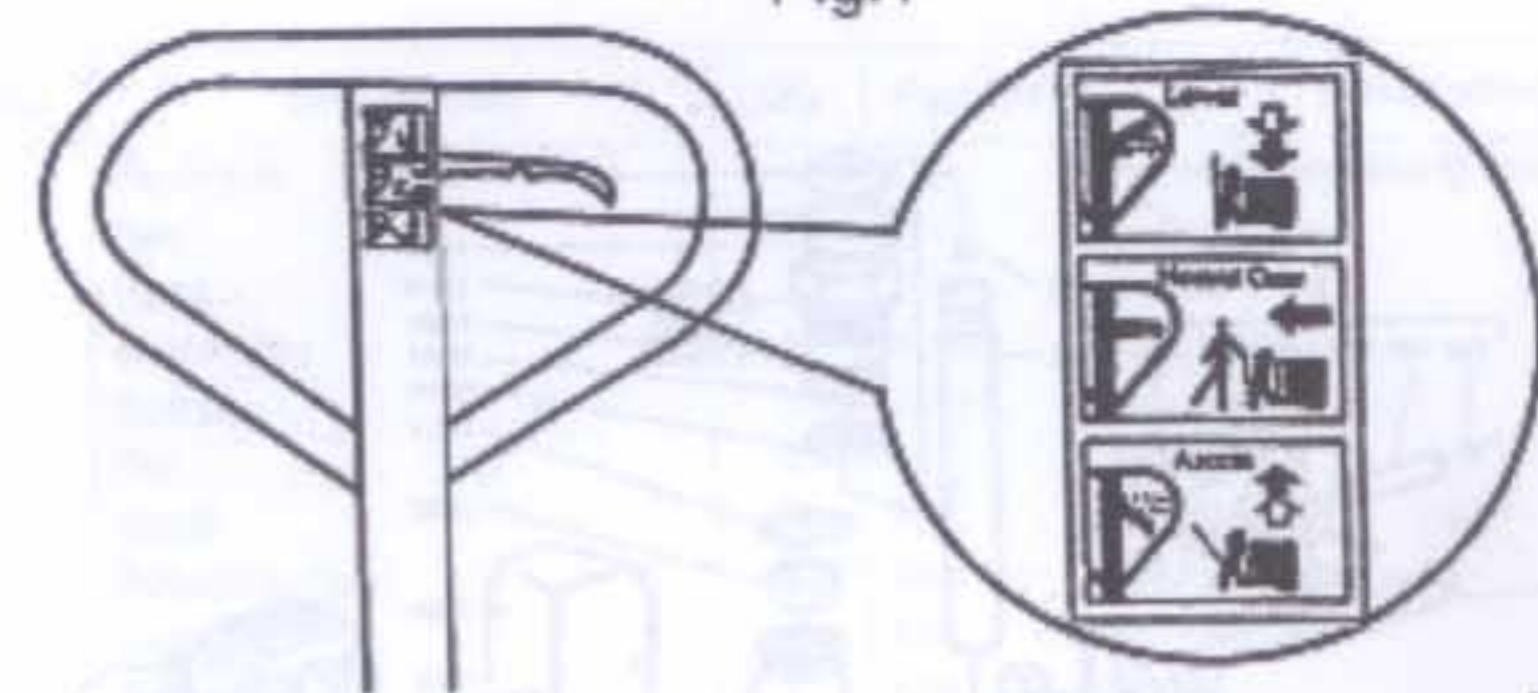
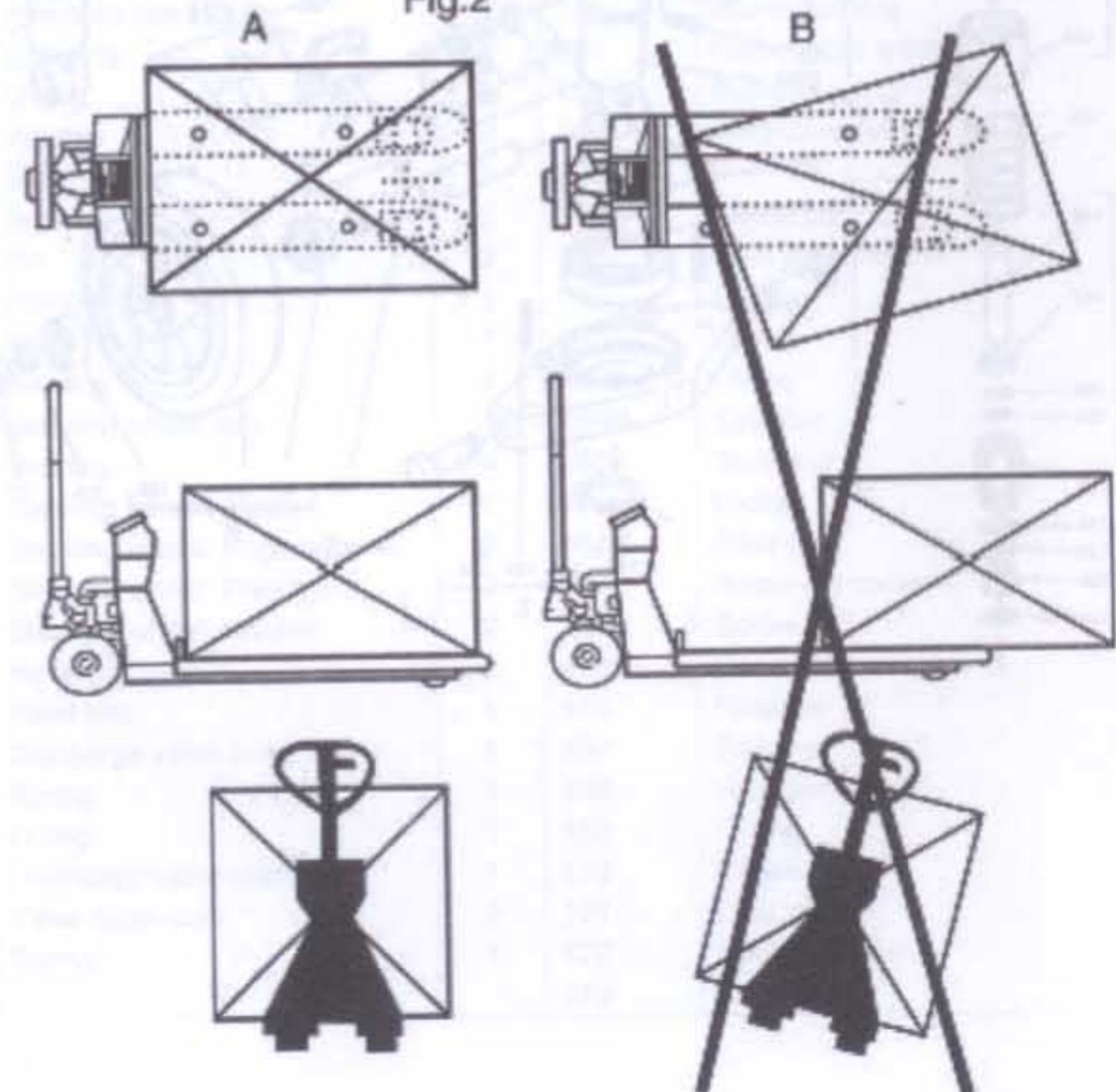
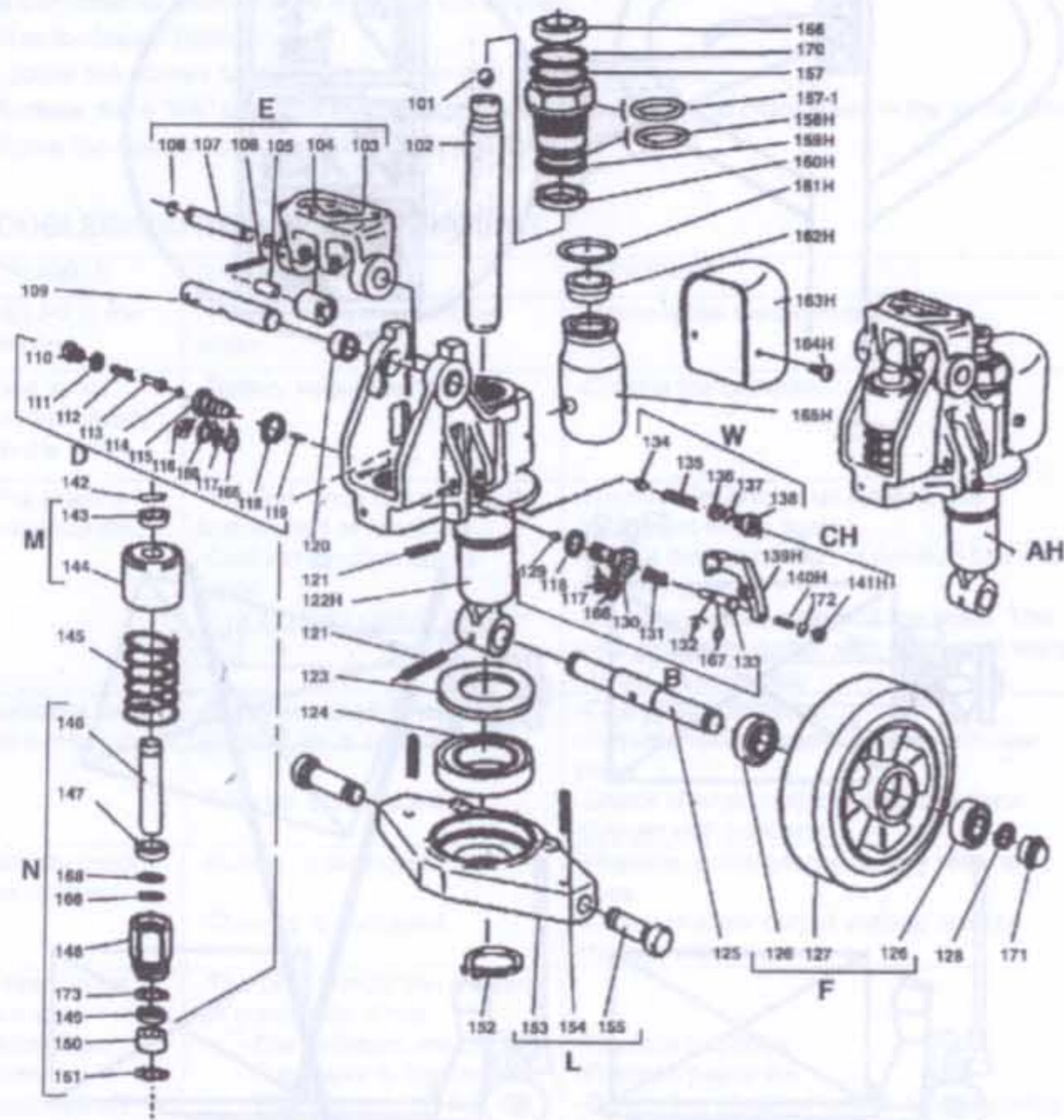

Fig.2



PARTS DRAWING OF PUMP ASSEMBLY



PARTS LIST OF PUMP ASSEMBLY

Part No.	Description	Qty	Part No.	Description	Qty
101	Steel ball	1	136	Pressure regulating screw	11
102	Rod	1	137	O-ring	1
103	Base	1	138	Screw	1
104	Steel roller	1	139H	Crank link	1
105	Bushing	1	140H	Setting screw	1
106	Pin	1	141	Nut	1
107	Shaft	2	142	Parallel pin	1
108	Retaining ring	1	143	Retaining cover	1
109	Axle	1	144	Spring cover	1
110	Screw	1	145	Spring	1
111	Washer	1	146	Pump rod	1
112	Spring	1	147	Dust proof ring	1
113	Pressure rod	1	148	Pump cylinder	1
114	Steel ball	1	149	Seal ring	1
115	Pressure valve body	1	150	Nylon bushing	1
116	Split ring	1	151	Red copper washer	1
117	O-ring	2	152	Retaining ring	1
118	Washer	2	153	Rhombus plate	1
119	Steel needle	1	154	Pin	2
120	Bushing	2	155	Dowel pin	2
121	Pin	2	156	Dust proof ring	1
122H	Pump body	1	157	O-ring	1
123	Dust cover	1	157-1	O-ring	1
124	Bearing	1	158H	O-ring	1
125	Steering wheel axle	1	159H	Cylinder	1
126	Bearing	4	160H	Seal ring	1
127A	Steering wheel, Nylon	2	161H	O-ring	1
127B	Steering wheel, Polyurethane	2	162H	Filler plug	1
127C	Steering wheel, Poly/Nylon	2	163H	Reservoir cover	1
127D	Steering wheel, Rubber	2	164H	Screw	2
128	Retaining ring	2	165H	Reservoir	1
129	Steel ball	1	166	Retainer	3
130	Discharge valve body	1	167	Retainer	1
131	Spring	1	168	Retainer	1
132	O-ring	1	169	O-ring	1
133	Discharge valve shaft	1	170	Retainer	1
134	Valve taper core	1	171	Dust cover	2
135	Spring	1	172	Spring washer	1
			173	O-ring	1

PARTS DRAWING OF HANDLE

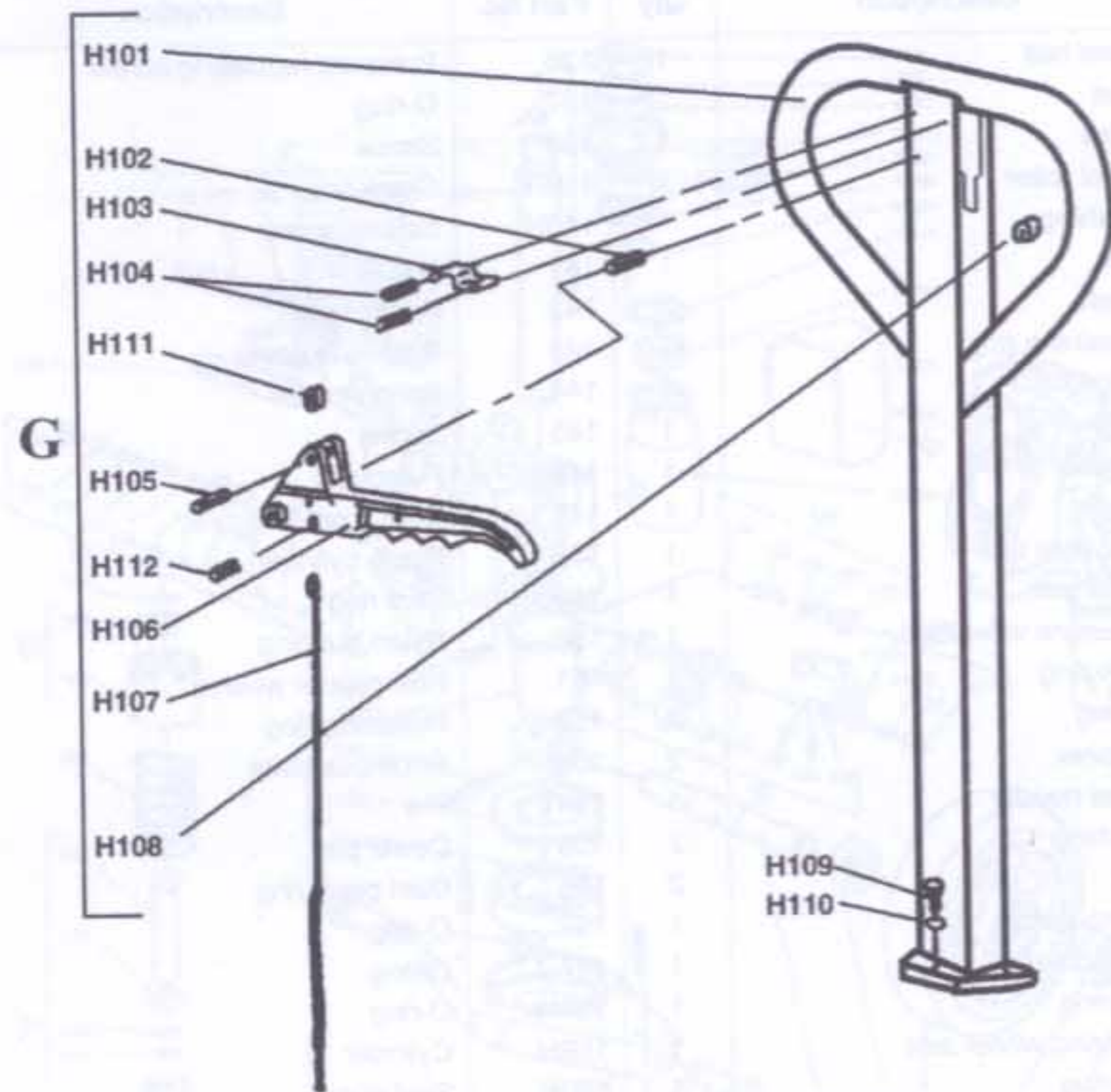

PARTS LIST OF HANDLE

Part No.	Description	Qty	Part No.	Description	Qty
H101	Handle	1	H107	Rod and chain	1
H102	Spring pin	1	H108	Rubber cushion	1
H103	Spring leaf	1	H109	Screw	3
H104	Spring pin	2	H110	Spring washer	3
H105	Spring pin	1	H111	Nylon roller	1
H106	Control lever	1	H112	Spring pin	1

PARTS DRAWING OF FRAME

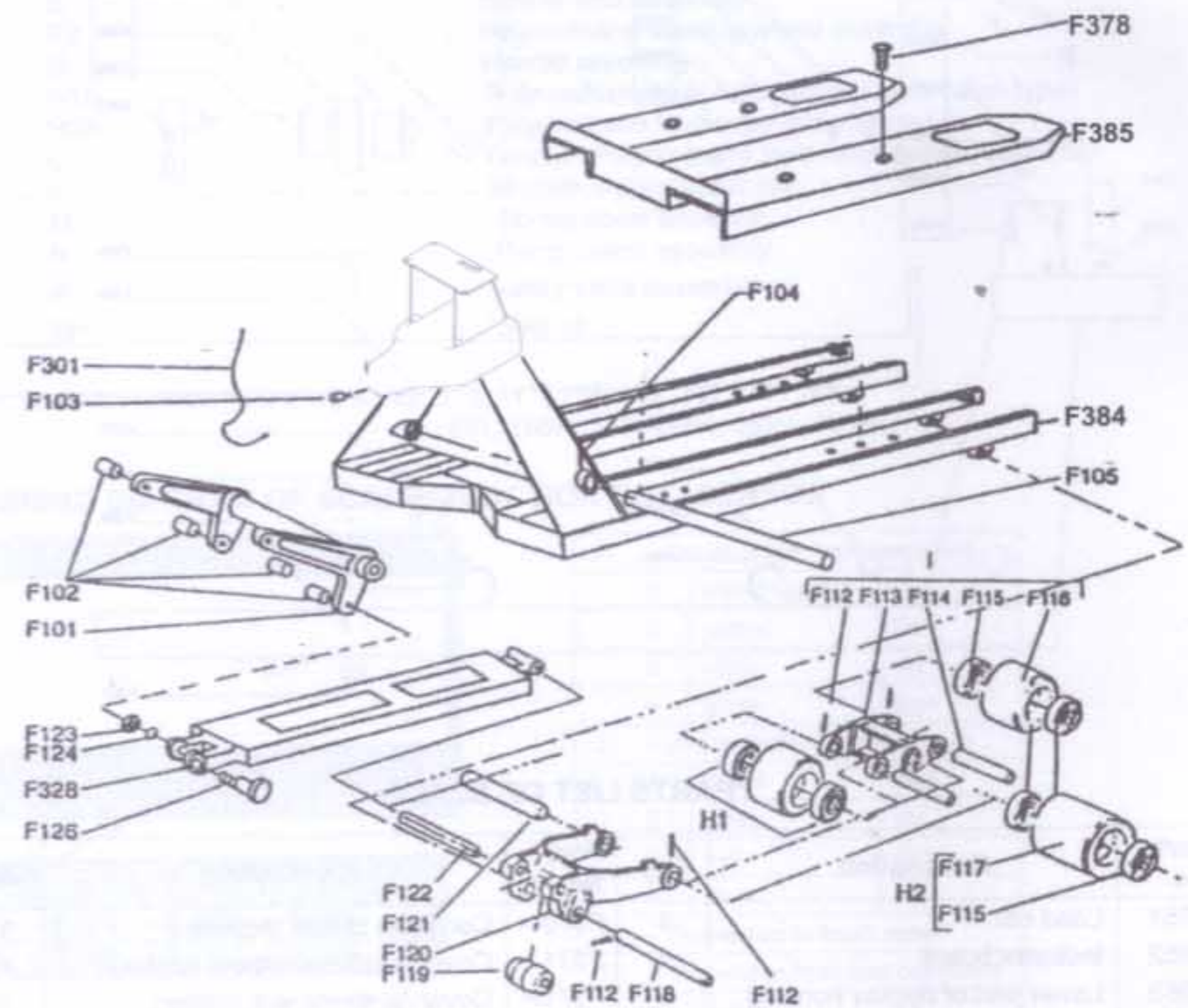

PARTS LIST OF FRAME

Part No.	Description	Qty	Part No.	Description	Qty
F101	Torsion tube assembly	1	F118	Axle	2
F102	Bushing	4	F119	Roller	2
F103	Hexagon socket screw	1	F120	Wheel frame	2
F104	Spring pin	1	F121	H-link axle	2
F105	Torsion tube shaft	1	F122	Pull rod axle	2
F112	Spring pin	8/4*	F123	Nut	2
F113	H-link	2	F124	Spring washer	2
F114	Load roller axle	4	F126	Eccentric pin	2
F115	Bearing	8/4*	F301	Signal wire	1
F116B	Poly load roller, tandem type	4	F328	Push rod	2
F117B	Poly load roller, single type	2			

Note*: Quantity for tandem roller is 8, for single roller is 4.

PARTS DRAWING OF SCALE

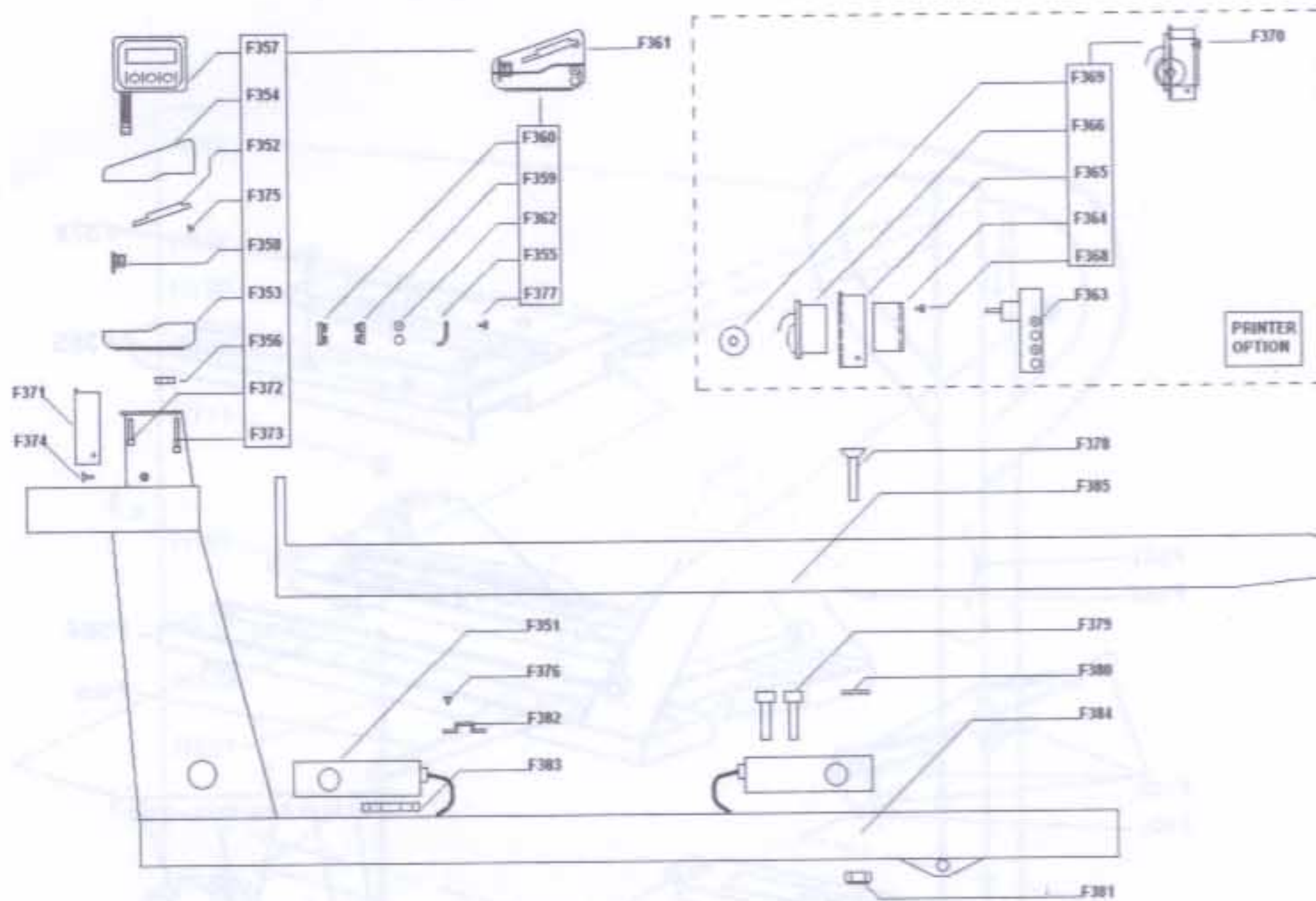

PARTS LIST OF SCALE

Part No.	Description	Qty	Part No.	Description	Qty
F351	Load cell	4	F370	Complete printer module	1
F352	Indicator board	1	F371	Cover (systems without printer)	1
F353	Lower part of display housing	1	F371P	Cover (systems with printer)	1
F354	Upper part of display housing	1	F372	Bolt M5x25	2
F355	Battery cover	1	F373	Bolt M5x40	2
F356	Rubber for cable enclosure	1	F374	Bolt M4x8	2
F357	Touch panel	1	F375	Bolt to secure indicator board	2
F358	Load cell connection board	1	F376	Bolt to mount cable support	4
F359	Battery contact clamp	2	F377	Bolt M3x8 for battery cover	2
F360	Battery contact clamp (double)	1	F378	Bolt M12x45	8
F361	Complete indicator	1	F379	Bolt M12x55	4
F362	Battery (rechargeable)	4	F380	Washer M12	4
F363	Charger incl. 4 batteries	1	F381	Nut M12 (self locking)	4
F364	Printer bracket	1	F382	Cable supports	2
F365	Mounting support for printer	1	F383	Load cell mounting plate	4
F366	Printer module	1	F384S	Chassis (1150 x 555)	1
F368	Screw for printer	3	F384L	Chassis (1150 x 690)	1
F369	Printer paper roll (per package of 5)	1	F385S	Double for shoe (1150 x 555)	1
			F385L	Double for shoe (1150 x 690)	1

ASSEMBLY LIST

Assembly	Description
AH	Pump unit
B	Lowering valve assembly
CH	Lowering screw assembly
D	Hydraulic valve assembly
E	Handle seat assembly
F2	Polyurethane steering wheel assembly
G	Handle assembly
H1B	Polyurethane load roller assembly (tandem type)
H2B	Polyurethane load roller (single type)
I2	Tandem Polyurethane load roller system assembly
L	Rhombus plate assembly
M	Spring cover assembly
N	Pump piston assembly
W	Safety valve assembly
SH	*Seal kit

*Note: Seal kit include following parts: 111, 117, 118, 132, 137, 147, 149, 151, 156H, 157, 158H, 160H, 161H.

10. WIRING DIAGRAM OF SCALE, JUNCTION BOX, SENSOR

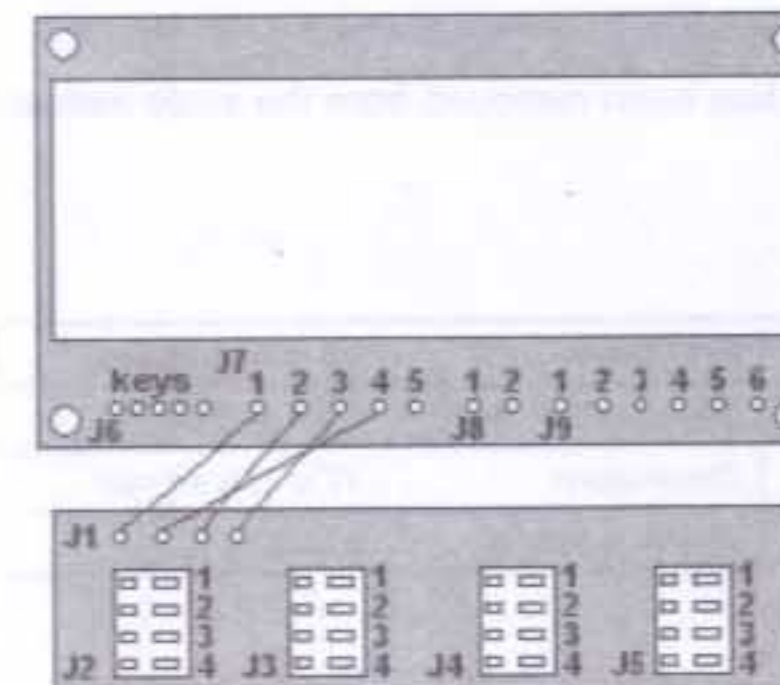



J1 - Connection to indicator board		
1	brown	Ex
2	yellow	Ex+
3	white	sig
4	green	sig+
J2 - J4 Connection from load cells		
1	green	sig+
2	white	sig
3	red	Ex+
4	black	Ex
J6 - Connection to touch panel		
J7 - Connection from load cell board		
1	brown	Ex
2	white	sig
3	green	sig+
4	yellow	Ex+
5		Sh
J8 - Connection from power supply		
1	black	Gnd
2	red	+6v
J8 - Connection to printer		
1		
2	red	+
3	green	TX
4	white	RX
5	black	CTS
6	yellow	RTS

11. PRINTER (OPTION)

11.1 Printer status LED

1. Flash "ON" -Printer is Off line
2. Always "ON" -Printer is On line
3. Flash "ON" -End of Paper
4. Flash "ON" -Over/under voltage

11.2 Printer buttons

-  On/off line
-  Paper feed

11.3 Printout

In the printout a gross weight is indicated with the letters "B/G" and a net weight with the letter "N". A keyed in tare weight will also be printed and is indicated with the letters "PT". The total weight is shown with the letters

"TOT".

Example printout:

01	B/G	6.8	kg	
02	B/G	158.2	kg	
03	N	426.5	kg	Out*
04	N	1200.0	kg	
04	PT	150.0	kg	
04	TOT	1791.5	kg.	

Out*: If the text "Out" is shown in a printout, then shown weight has been removed from the scale instead of added.

11.4 Specifications:

Printer	:Thermal	Print speed	:up to 45 mm/sec.
Functionality	:Manual paper feed	Temperature range	:0 tot +40°C
Paper	:Thermal roll, roll diameter maximum 32 mm, width 58mm	Dimensions	:77 x 77 x 44 mm
Resolution	:203 DPI	Power supply	:6 Vdc

11.5 Changing the paper

Turn off the weighing system. Pull the lever until the cover group is released from its locking position. To avoid damage to the lever do not use excessive force.

Insert the paper roll with the **loose end at the top and pointing forward** at the top of the printer.

Hold on to the loose end when closing the printer, so that it will be visible once the printer is closed. To close the printer: Press on both sides of the cover group simultaneously.

Or Press on the middle of the cover group, near the paper exit. To cut the paper correctly: Pull the paper towards the tear bar from one side to the other.

